

V1.11

# INSTALLATION GUIDE



CAR MEDIA SYSTEMS



## VN940-4G

**SMART NAVICEIVER**  
**MOBILE INTERNET READY**  
VISION ANDROID™ SERIES

## IMPORTANT NOTES

---

**This guide is an aid for the professional installation of the device.**

**Please note the following notes before installation:**

- Always handle all parts of the device and the components of your vehicle with care.
- Under all circumstances observe the regulations of the vehicle manufacturer and do not make any changes to the vehicle which could impair driving safety.
- For safety reasons, disconnect the vehicle battery's ground connection before installation.
- Please always pay attention to the correct polarity of the connections.
- Please do not modify any harnesses or connections of the device or the vehicle as this may affect the warranty.
- Make sure that no cables are squashed or cause a short circuit.
- Do not lay cables in front of the airbags, e.g. in the dashboard or in a way that affects their function.

 **NOTE:**

For many vehicle models, a vehicle-specific 1-DIN installation set is required for professional installation. In order to be able to use the existing steering wheel remote control of your vehicle, a vehicle-specific adapter may also be required. You can obtain information about this on the Internet or from your specialist dealer.

## INSTALLATION HINTS

---

Please note the following steps when installing the device:

- 1 Original radio / navigation system**  
If available, first remove the original radio / navigation device. Use suitable unlocking tools to pull the device out of the dashboard. Then pull the cable plug from the device and leave it accessible in the radio slot.
- 2 Cabling of the ESX main device**  
Lay the supplied cable sets and antennas in the vehicle. Please note the information on the next page. Then connect all cable sets, antennas and dongles to the ESX main device as described on page 6. Then plug in the cable plug from the radio slot of the vehicle on the ESX main unit or on its vehicle-specific system cable set.
- 3 Installation of the ESX main device**  
Now the ESX main device can be inserted into the 1-DIN installation slot of the vehicle.
- 4 Functional test**  
Before you complete the installation, you should perform a function test. Check all functions of the ESX naviceiver including the steering wheel remote control of the vehicle.

## RECOMMENDED TOOLS

---



 T25

Torx T25 screwdriver or bit



Phillips screwdriver

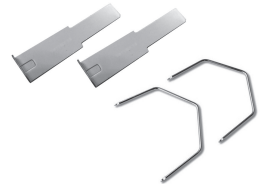

Unlocking tools









Cable ties





Plastic mounting wedges

## SCOPE OF DELIVERY

ITEM	FIGURE	QUANTITY
Main device		1
ISO system cable set (20-pin connector)		1
AV cable set 1 with audio and video connections incl. rear view camera (14-pin connector)		1
USB port 1 (4-pin connector)		1
4G/LTE dongle (6-pin connector)		1
USB port 2 (8-pin connector)		1
Camera cable set for HD rear view camera (10-pin connector)		1

## SCOPE OF DELIVERY

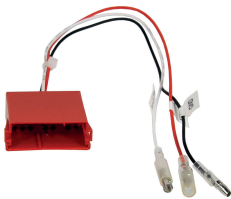
ITEM	FIGURE	QUANTITY
<p>AV cable set 2 with power, audio and video connections, additional camera input (8-pin connector)</p>	<p>G</p> 	<p>1</p>
<p>External microphone (6-pin connector)</p>	<p>H</p> 	<p>1</p>
<p>GPS antenna</p>		<p>1</p>
<p>DAB antenna</p>		<p>1</p>
<p>4G/LTE antenna</p>		<p>1</p>
<p>VNA-LFB-FD6 Adapter for analog steering wheel remote control (Only VNC940-DBJ-4G and VNC945-DBJ-4G)</p>		<p>1</p>

## WIRING DIAGRAM

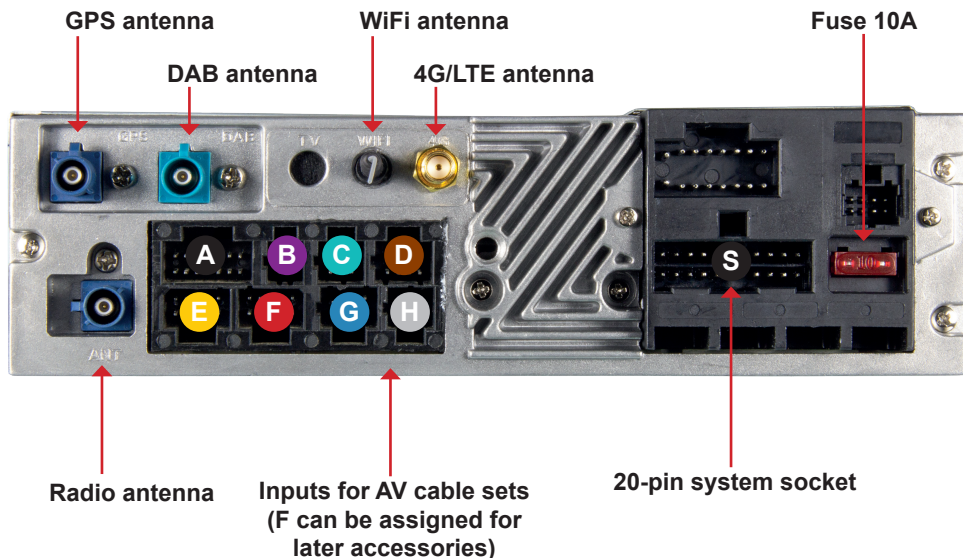

### Assignment system socket

#### **S** System cable set 1 (20-pin connector, black)

<b>Cable brown (BRAKE):</b>	Connection for handbrake signal (ground)
<b>Cable pink (BACK):</b>	Connection for reverse gear signal (+ 12V)
<b>Cable white (KEY1):</b>	Connection for analog steering wheel control (left)
<b>Cable black/white (KEY2):</b>	Connection for analog steering wheel control (right)
<b>Cable brown/black (CAN-RXD):</b>	Currently not used
<b>Cable black (GND)*:</b>	Ground connection for devices such as cameras
<b>Cable orange (AMP CON)**:</b>	Remote turn-on signal for external amplifiers (+12V)

\* only on the new model generation since May 2021

\*\* must be activated in the Naviceiver in the app "DSP" under "EXT AMP"

#### **⚠ NOTE:**

The handbrake signal must be connected to BRAKE. When the handbrake is applied, the signal must be connected to ground. According to legal regulations, the device may only play videos on the main screen when the handbrake is engaged. The connection cable must therefore not be permanently connected to ground. While driving, the screen is switched off to avoid accidents caused by carelessness.

### Assignment of AV connections

#### **A** AV cable set 1 (14-pin connector, black)

<b>RCA white (FL):</b>	Audio output Front/Left
<b>RCA red (FR):</b>	Audio output Front/Right
<b>RCA white (RL):</b>	Audio output Rear/Left
<b>RCA red (RR):</b>	Audio output Rear/Right
<b>RCA green (SUB WOOFER):</b>	Audio output Subwoofer
<b>RCA yellow (VIDEO OUT 1):</b>	Video output for external monitor 1
<b>RCA yellow (VIDEO OUT 2):</b>	Video output for external monitor 2
<b>RCA yellow (AUX-V):</b>	Video input for an external signal source
<b>RCA yellow (REAR-CAMERA*):</b>	Video input for rear view cam

\* or REV-V

#### **D** USB port 2 (8-pin connector, brown)

Use this USB port in conjunction with the Media Connect function to connect your smartphone to the Naviceiver.

#### **E** Camera cable set for HD rear view cam (10-pin connector, yellow)

<b>RCA yellow (AHD-CAM):</b>	Video input for high resolution rear view camera (Only for compatible HD cameras)
------------------------------	--

#### **G** AV cable set 2 (8-pin connector, blue)

<b>RCA red (AUX-RIN):</b>	Audio input AUX/Right
<b>RCA white (AUX-LIN):</b>	Audio input AUX/Left
<b>RCA yellow (FRONT-CAMERA*):</b>	Video input for the front or additional camera
<b>Cable yellow (CCD+12V):</b>	Power cable for all cameras
<b>Cable black (GND):</b>	Ground cable for all cameras
<b>Cable brown (BRAKE):</b>	Connection for handbrake signal (ground)

\* or F-CAMERA

## GENERAL INSTALLATION INSTRUCTIONS

---

### GPS antenna

The GPS antenna must be glued horizontally to the front of the dashboard. No reception is possible if the window is metallized. Choose a flat spot with a clear view of the sky. The location must be about 50 cm away from the main unit, otherwise the GPS measurement accuracy will be reduced. When installing the GPS antenna in the vehicle, the GPS accuracy is determined by the installation position and body shape of the vehicle. The accuracy is usually lower when the GPS antenna is installed in the vehicle.

Remove the film on the underside of the GPS antenna



### DAB antenna

Route the DAB antenna to the windshield and attach it there.

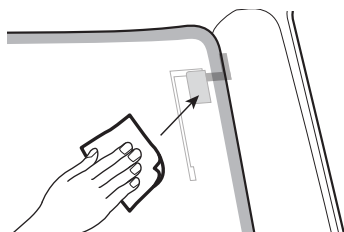

Clean the windshield with a suitable cleaning cloth.

#### NOTE:

In newer vehicles, the original vehicle antenna can usually be used for both analogue and digital radio reception. The enclosed DAB window antenna should only be used if no fender or roof antenna is available.

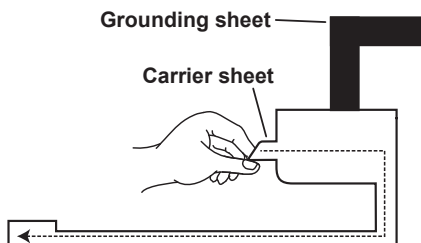

Remove the carrier sheet of the black amplifier unit and the foil antenna and stick the antenna to the window.

Glue the copper-colored metal surface of the grounding sheet to a bare metal part of the vehicle.

### External microphone

The external microphone should be positioned in an easily accessible location, e.g. next to the sun visor or on the steering column.

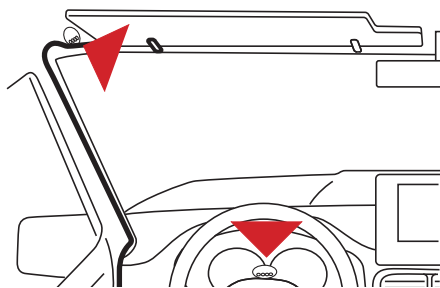

### USB ports

Route the USB ports to the desired location, e.g. to the glove compartment.



## SETUP THE 4G/LTE INTERNET CONNECTION

---

1. First lay the two 4G/LTE antennas inside the dashboard towards the windshield, one antenna for the left and one for the right.
2. Ideally, you should stick the antennas to the windshield to ensure optimal reception.
3. Then insert your SIM card in the 4G/LTE dongle:



Open the dongle by pushing the flap to the right.

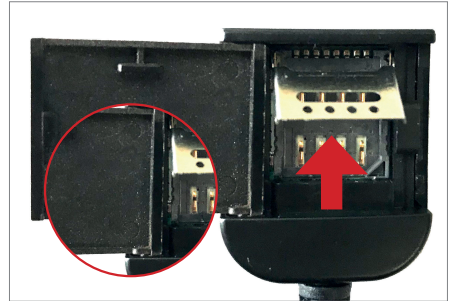

Now open the metal flap carefully with a suitable tool by pushing the flap up.

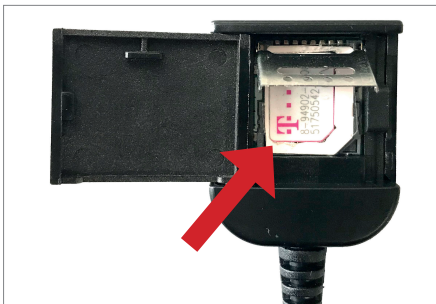

Then insert your SIM card with the contacts facing down.

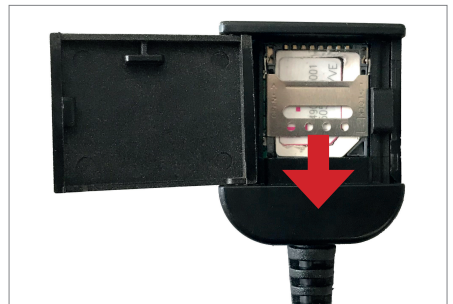

Close and lock the metal flap carefully by pushing the flap down.

### Compatible SIM cards:



Micro SIM



Nano SIM with adapter for Micro SIM

## SETUP THE 4G/LTE INTERNET CONNECTION

---

### 4. Then turn on the device to test the 4G/LTE connection.

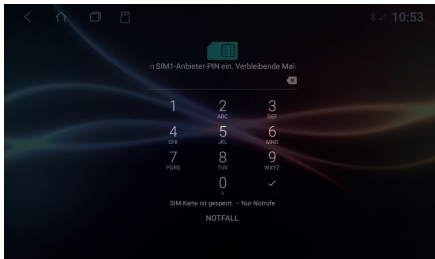

After the device has started, enter your 4-digit PIN code of the SIM card here. Confirm the entry with the tick.

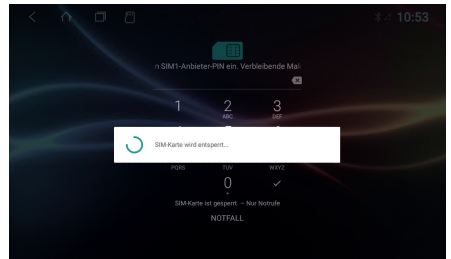

After successful entry, the SIM card is unlocked.

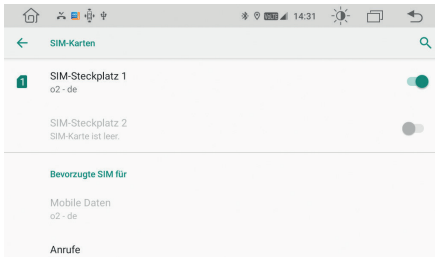

If the device is successfully connected to the mobile Internet, the „LTE“ symbol appears in the status bar at the top right.

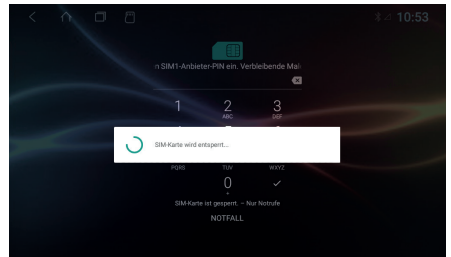

If the device is turned off, you have to enter the PIN code of the SIM card again after each restart, just like with a smartphone\*.

### 5. After a successful test, install the 4G/LTE dongle in the radio slot or dashboard.

\* The SIM card's PIN query can be deactivated in standard smartphones. To do this, insert the SIM card in a smartphone and deactivate it accordingly. The steps involved vary depending on the smartphone.

## TECHNICAL DATA / RADIO SYSTEM TYPE

---

Function	Band Information	Frequency Range	Max. emitted power
Satellite System	GPS GLONASS	1.575 MHz 1.602 MHz	–
AM Radio	Medium wave	520 - 1.700 Hz	–
FM Radio	Band II	87,5 - 108 MHz	–
DAB Radio	Band III (5A – 13F)	174,9 - 239,2 MHz	–
4G / LTE	FDD (Band 1 / 3 / 5 / 7 / 8 / 20) TDD (Band 38 / 39 / 40 / 41)	800 - 2.100 MHz 1.900 - 2.600 MHz	22,3 dBm 21,9 dBm
3G	WCDMA (Band 1 / 5 / 8)	900 - 2.100 MHz	22,8 dBm
Bluetooth	Version 5.0	2.400 MHz - 2.484 MHz	30,0 dBm
WiFi / W-LAN	IEEE802.11b/g/n	2.400 MHz 5.000 MHz	16,0 dBm 13,0 dBm



CAR MEDIA SYSTEMS



ESX Car Media Systems · Audio Design GmbH  
Am Breilingsweg 3 · D-76709 Kronau/Germany  
Tel. +49 7253 - 9465-0 · Fax +49 7253 - 946510  
[www.esxnavi.de](http://www.esxnavi.de) - [www.audiodesign.de](http://www.audiodesign.de)

© All rights reserved. Subject to technical changes and errors.